

## TECHNICAL NOTES



FENICE®

A range of motorised mounting solutions and accessories



# The Fenice<sup>®</sup> range

Fenice is a range of motorized mounting solutions.

**FE2** A series of motorized lifting column kits.

**FE2W** A series of brackets and interfaces to suit the FE2 range

The following models within the range are discussed at length in another technical document.

**FE3** Small motorized wall bracket

**FE4** Large motorized wall bracket

**FE5** Motorized ceiling pole mount

**FE6** Motorized plasma trolley

## **FE2 MOTORISED LIFTING COLUMNS**

The Fenice FE2 Lifting Column is a patented telescopic lifting column designed for use in AV, IT, Home Automation and other applications where an automatic lifting function is required.

The Fenice FE2 is made up of three steel tubes with a 24VDC motor-gear box assembly fitted inside. This design safely achieves a very low noise operation, a basic requirement for most applications.

There are three different size columns designed to match most LCD & Plasma TVs. All three columns have the same maximum load capacity of 80kg and are capable of lifting most existing LCD & Plasma TVs, sized from 15 to 65 inches.

Installation and connection of the system is extremely easy. Just four screws are required to fix the lifting column into a cabinet or wall panel. The connections between all the main parts, such as the lifting column, control box, switch box and IR receiver are unique plug types. This design allows simple installation, maintenance and repair or replace of each component.

Each column is equipped with an infrared remote control and a wired Switch Box. This secondary device allows the end user to utilise the column even if the remote control is lost or misplaced.

A unique control box featuring a “SMART” micro-processor allows for basic operating functions; Up/Down/Store/Recall etc. whilst also providing a self-protection feature. This feature monitors the current voltage consumption, immediately shutting down the column if an abnormal rise of current is detected.

The control box is CE and UL approved. This guarantees it complies with the necessary safety requirements.

Optional mounting brackets and interfaces allow maximum flexibility, enabling most LCD & Plasma TVs to be simply fitted onto the lifting columns.

There are three models in the FE2 series of lifting columns, they are the FE2A, FE2B and FE2C.

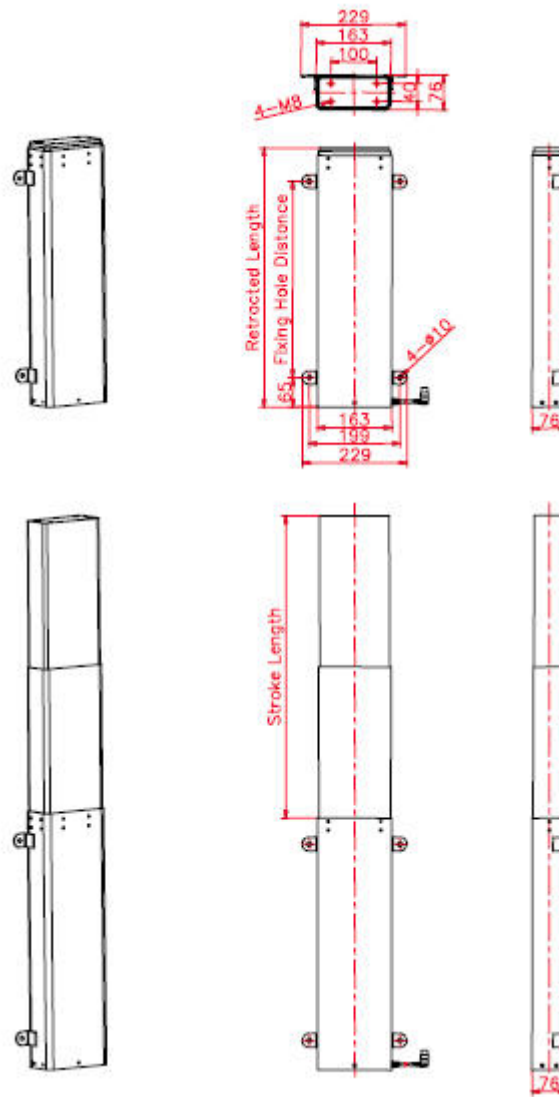

Model	Retracted Height	Stroke	Load	Fixing Holes	Extended Height
FE2A	570mm / 22.5"	650mm / 25.5"	80kg/175lbs	430mm	1220mm / 48"
FE2B	685mm / 28"	780mm / 30"	80kg/175lbs	545mm	1465mm / 58"
FE2C	795mm / 31.5"	914mm / 36.5"	80kg/175lbs	650mm	1709mm / 68"

The stroke is the amount of distance the top of the column moves between the retracted and extended heights. The formula is:

$$\text{RETRACTED HEIGHT (X)} - \text{EXTENDED HEIGHT (Y)} = \text{STROKE (Z)}$$

For example the FE2C is 795mm / 31.5" in its retracted position, let's call that height "X", in its extended position the height is 1709mm / 68", let's call that height "Y". The stroke, which in this case is 914mm / 36.5" we will call "Z" is the difference between X-Y.

Hence the FE2C with a retracted size of 795mm and an extended height of 1709mm therefore it has a stroke of the difference between the two, being 914mm.

**Features**

The units can be utilized in all planes, either to push up a screen, lower a screen or slide one along. The effectiveness of the unit in these other planes varies and caution should be taken when recommending the units for these installations.

Generally speaking it would be prudent to allow a 50% reduction in weight capacity for lowering movements and 25% reduction in weight capacity for sliding movements.

Skunkworks does not supply cabinets or plans for such however we do recommend joiners who use the Fenice in their existing cabinets or who can customize cabinets to include the FE2 models. A list of these is available on application.

The Fenice FE2 solution is patented and somewhere around one third the price of existing more complicated lifting systems.

The warranty period for the Fenice is three (3) years.

**International Models**

There are three international configurations in this range, for the US (110V), for the Middle East (220V) and for Europe, UK and Australia (240V)

**Included in each kit**

The FE2 series come complete with IR receiver, IR Remote, Manual Switch, Controller Box and the column itself.

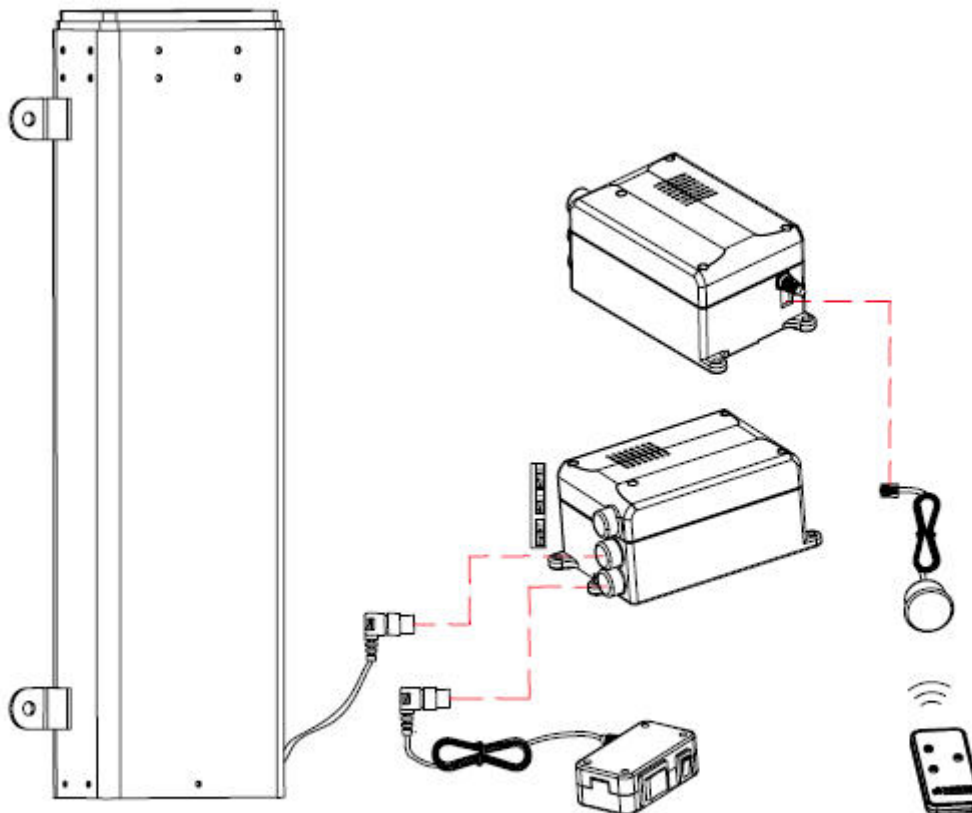

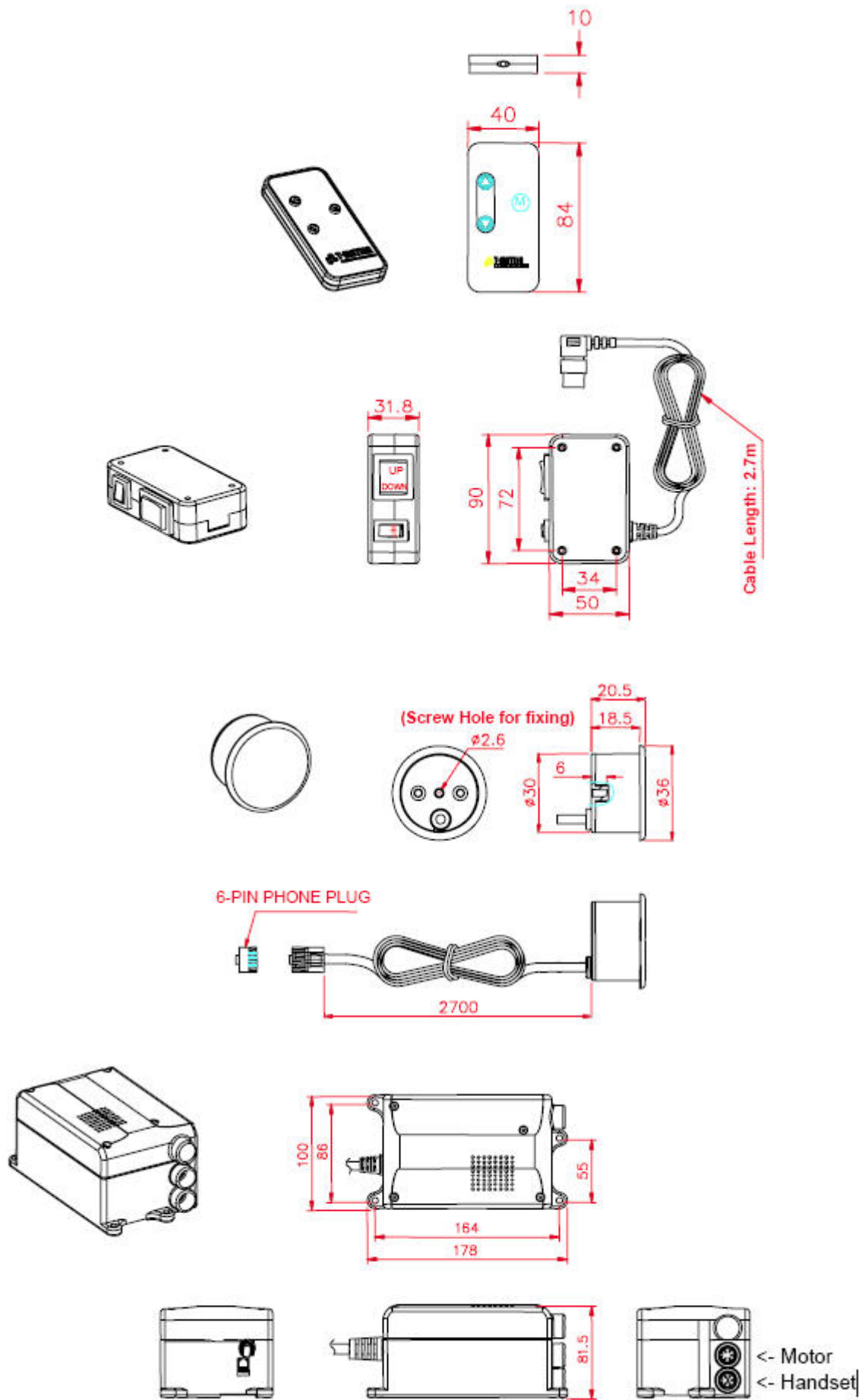

### **FE2W BRACKETS AND INTERFACES**

The FE2W is a series of brackets and/or interfaces suitable for the FE2 series columns.

The FE2W0 is both an interface and bracket.

As an interface it is designed to allow most of the existing Skunkworks' brackets to be attached to it and then onto a Fenice FE2 lifting column.

As a bracket it features standard VESA compliant mounting holes, enabling many screens to be attached directly, without the need of a further bracket or mounting.

For example, when used as an interface the FE2W0 could allow a Sterling 174 (wall mounted slim bracket with swivel, tilt and rotate) to be attached to a Fenice Lifting column, giving the installer the ability to not only lift a screen but also manual adjust its tilt, swivel and angle of rotation.

When utilized as a bracket, the FE2W0, with its 75x75mm, 100x100mm, 200x100mm and 200x200mm mounting holes allows the installer to fit any screen fitting those VESA measurements directly to it and then onto a FE2 Fenice lifting column.

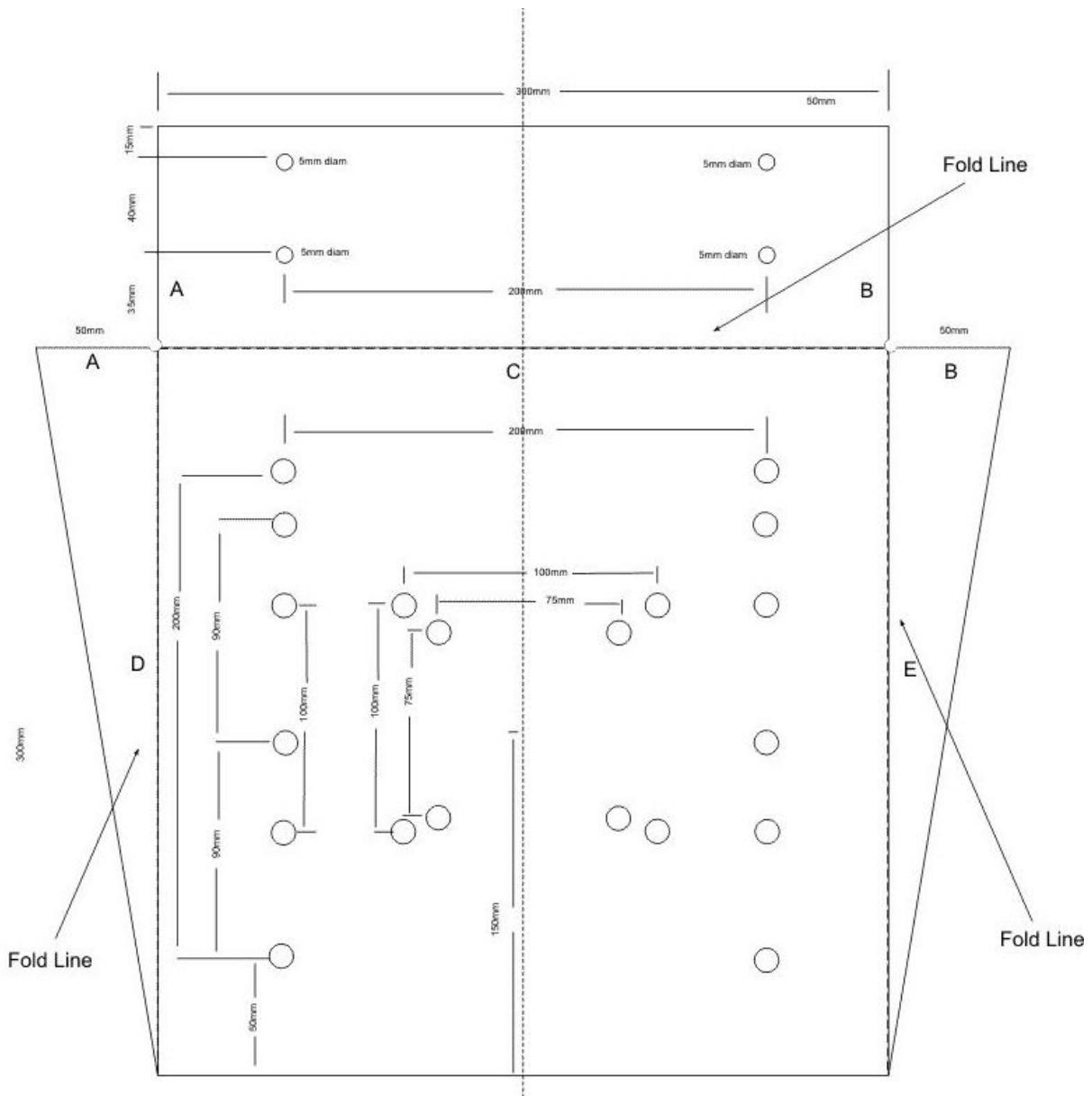

***FE2W0 Interface / Bracket***

The FE2W1, FE2W2 and FE2W3 are brackets designed to fit varying size screens. They include an interface and rails. The rails connect to the screen, the screen to the interface panel and then on to the column. The three models vary only in the size screen they can hold. Roughly speaking the largest is normally suited to the 65" screen size, the middle one for 40" and the smallest down to a 26". This is not a fixed formula and the technical specifications will allow the customer the ability to choose the correct model.

Model	Mounting Configuration	Load	Screen Sizes (approx)
FE2W0	75x75, 100x100, 100x200, 200x200mm	80kg/175lb	15"-32"
FE2W1	up to 410x550 mm	50kg/110lb	15"-32"
FE2W2	up to 450x660mm	50kg/110lb	26-37"
FE2W3	up to 510x760mm	65kg/140lb	37"-65"

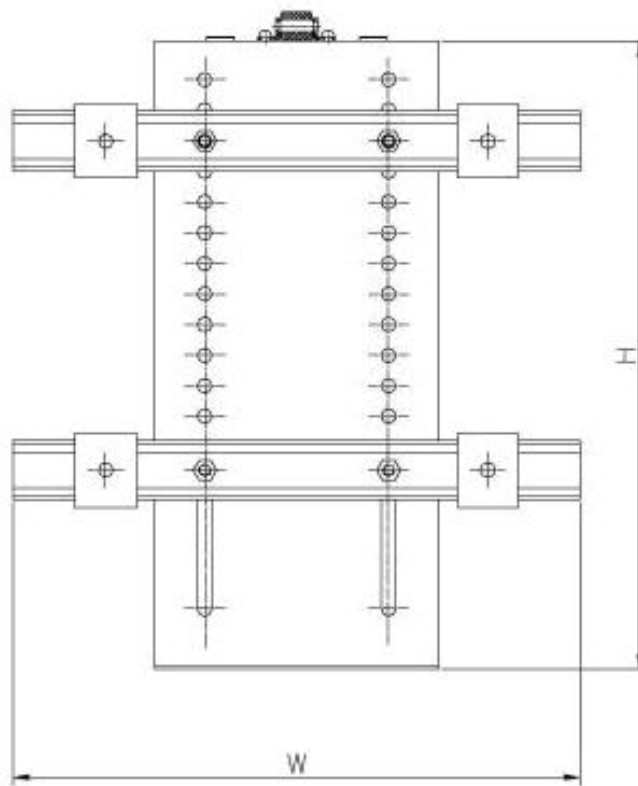

	W	H
L	760	510
M	660	450
S	550	410

**FE2W1,2 and 3 Brackets and rails**

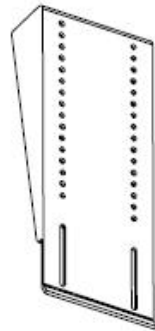

FE2W3

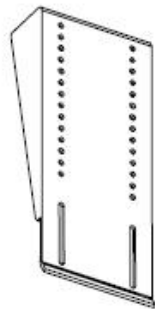
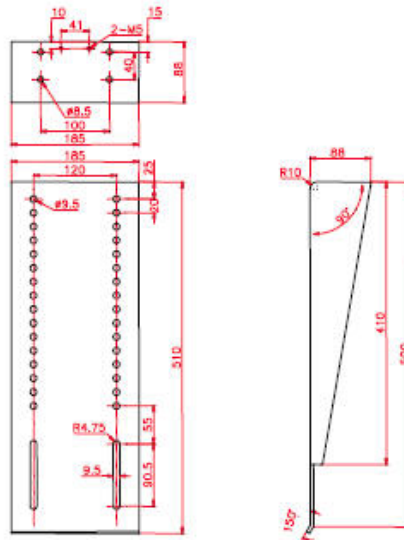

FE2W2

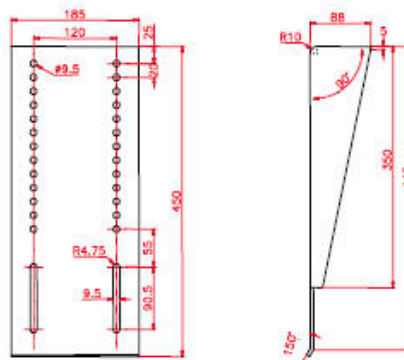

FE2W1

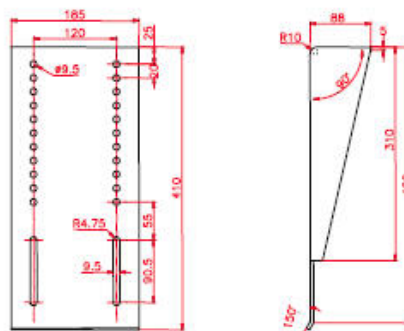

**FE2W1,2 and 3 Brackets**

**Included in each model**

The FE2W0 is supplied without accessories whilst the FE2W1, FE2W2 and FE2W3 come complete with rails and all mounting hardware including a small roller that when fitted to the top of the interface panel allows the unit to push open the top hinged lid of any specially built cabinet.

No.	Drawing	Description	Q'ty
1		Wheel ( $\phi 18 * \phi 8 * 20L$ )	1
2		Shaft ( $\phi 8 * 28L$ )	1
3		Shaft Holder ( $15 * 15 * 10$ )	2
4		Screw (M5*7L)	2
5		Manual Screw (M5*10L)	1
6		Washer (M8)	12
7		Slider	3
8		Slider (with fixing hole)	1
9		Screw (M8*15L)	12
10		Handle	1

***FE2W1,2 and 3 Parts listing***

**NOTE:**

As with all Skunkworks products, the specifications and features of the FE range of products vary from time to time. It is prudent to purchase all items and supply these to your installer or cabinet manufacturer before any construction work begins.